

# Clearing Inter-Platform API Specification

Stand: **07.05.2026**

Version: **1.1.1**

## Notice

Copyright © by the Authors 2025 and Arbeitskreis Schnittstellen und Prozesse. All Rights Reserved.

This document and translations of it may be copied and furnished to others, and derivative works that comment on or otherwise explain it or assist in its implementation may be prepared, copied, published, and distributed, in whole or in part, without restriction of any kind, provided that the above copyright notice and this section are included on all such copies and derivative works.

License might be changed, and the document might be published under open-source license at a later point in time based on agreements with "Arbeitskreis Schnittstellen und Prozesse".

## Authors

 <p><b>BITConEx GmbH</b></p>	<p>Contact Halid Zehic Tel.: +49 (0) 160 / 7839658 <a href="mailto:halid.zehic@bitconex.de">halid.zehic@bitconex.de</a></p>
 <p><b>holos supply GmbH</b></p>	<p>Contact Rene Schäflein Tel.: +49 (0) 1522 278 17 18 <a href="mailto:rene.schae flein@holosupply.de">rene.schae flein@holosupply.de</a></p>
 <p><b>ARBEITSKREIS SCHNITTSTELLEN &amp; PROZESSE</b></p>	<p>Contact <a href="#">Kontaktformular</a></p>

1	Introducing connected platforms	2
2	Version compatibility	3
2.1	Compatibility matrix	3
2.2	Compatibility rules	3
3	Syncing tickets between platforms	4
3.1	Trouble Ticket Sync Event	5
3.1.1	Create Ticket	6
3.1.2	Set Status	6
3.1.3	Set Resolved	7
3.1.4	Change Severity	7
3.1.5	Add a Note	8
3.1.6	Change Data	8
3.2	Request Ticket Cancellation	9
3.3	Request Customer Migration	10
3.4	Access control	13
4	Syncing carriers between platforms	13
4.1	Handling of Non-Clearing Organizations (NCOs)	16
5	Attachments	16
6	Checking tickets	17
6.1	Access Control	17
7	Operational Exception Guidelines	18
7.1	Failure Handling Principles	18
7.1.1	Technical errors	18
7.1.2	Logical errors	18
7.1.3	Illegal requests	19
7.2	Unexpected situations	19
8	Customer Migration Between Platforms	19
8.1	Preconditions	20
8.2	Process overview	20
8.3	Migration error handling	21
9	Open Issues	21
9.1	Unexpected situations	22
9.2	Automatic cancellation	22

## Clearing Inter Platform REST API Specification

9.3 Other Topics	22
10 Change Log	22
10.1 Version 1.0 to Version 1.1	23
10.2 Version 1.1 to Version 1.1.1	23

# 1 Introducing connected platforms

The Inter-Platform API specification defines the mechanisms by which clearing platforms exchange data within a multi-platform network.

A clearing platform is a system that fully implements the official Clearing Specification, which consists of:

- [\[MAIN-1\] Clearing Platform REST API Specification](#)
- [\[REF-4\] Clearing Platform Metadata](#)
- [\[REF-6\] Clearing Platform Specification Test Cases.xlsx](#)
- [\[REF-7\] Clearing Platform NCO handling V.1](#)

The following documents are also part of this specification

- [\[REF-1\] Inter-Platform API V1.1.yaml](#)
- [\[REF-2\] Inter Platform Specification Test Cases.xlsx](#)

A platform can only participate in inter-platform communication if it has successfully implemented this specification. This ensures interoperability and minimizes the likelihood of rule validation exceptions during data synchronization.

***Note:** The successful implementation of the clearing specification must be demonstrated in an appropriate and verifiable way before onboarding into the inter-platform network. There is a test plan that must be verified by at least one of the existing platforms.*

All platforms within the multi-platform network need to know each other.

For the distribution of the relevant information, there is no dedicated API. Instead, this process is handled informally by the UAG Clearing group.

- Each platform is identified by a unique ITU Carrier Code.
- Each platform must provide all other platforms with:
  - the base URL of its Inter-Platform API
  - a set of OAuth2 credentials for secure communication

## Clearing Inter Platform REST API Specification

## 2 Version compatibility

### 2.1 Compatibility matrix

This matrix defines which Clearing Platform versions are supported by each Inter Platform version.

Version	Referenced	Compatible	Notes
1.0	1.1	1.1, 1.2, 1.2.1, 1.2.2	Baseline mapping
1.1	1.2.2	1.2.2	Added unsupportedScenarios support
1.1.1	1.2.2	1.2.2	Clarified that supported scenario validation is only performed for the receiver role during create ticket processing.

- Version: Inter-Platform specification version.
- Referenced: Clearing Platform version used as the baseline/reference for this Inter Platform version.
- Compatible: Additional Clearing Platform versions validated as compatible for this Inter Platform version.
- Notes: Important context for compatibility decisions.

Note: Only listed version combinations are supported. Unlisted combinations are not supported/not validated.

## 2.2 Compatibility rules

- Inter Platform is pinned to a specific Clearing Platform version.
- Clearing Platform updates that do not change models referenced by Inter Platform are compatible without Inter Platform version bump
- Clearing Platform updated that do change models require an Inter Platform update

Example:

Clearing Platform - Active version: c.n Next version: c.n+1

Inter Platform - Active version: i.n Next version: i.n+1

- **Case A:** Clearing c.n+1 has no changes in Inter-referenced models
  - Inter i.n remains compatible.
  - No Inter API version bump required.
  - Matrix can be extended:
    - i.n -> c.n, c.n+1 (compatible by unchanged referenced models)
- **Case B:** Clearing c.n+1 changes a referenced model
  - Inter i.n becomes incompatible (or conditionally incompatible).
  - Release new Inter version (e.g. i.n+1) aligned to Clearing c.n+1
  - Matrix update:
    - i.n -> c.n
    - i.n+1 -> c.n+1

## 3 Syncing tickets between platforms

### 3.1 Trouble Ticket Sync Event

For syncing tickets between platforms there is just one sync method

```
/listener/troubleTicketSyncEvent:
  post:
    tags:
      - NotificationListener
    summary: Client listener for ClearingTicket sync event
    description: Client listener for receiving the ClearingTicket sync
      notification
    operationId: listenToTicketSyncEvent
    requestBody:
      description: The event data
      content:
        application/json;charset=utf-8:
          schema:
            $ref: '#/components/schemas/ClearingTicketEvent'
      required: true
    responses:
      '200':
        description: OK - Notified
        content: {}
    x-codegen-request-body-name: data
```

The request body of type `ClearingTicketEvent` contains

- The **initiator** of the request (ITU-Code)

#### Clearing Inter Platform REST API Specification

- the entire **clearing ticket** – schema according to the most recent specification (see [\[MAIN-1\]](#) [\[REF-4\]](#))
- the **event type** (enum)
  - **CREATE**
  - **STATUS**
  - **RESOLVED**
  - **NOTE**
  - **DATA**
  - **SEVERITY**

**Reason:** The tickets on either platform must be **exactly** in sync.

**Benefit:** We can just take the ticket as is and replace it on the target platform while still knowing the reason for this notification. This helps to notify the connected partners properly.

### 3.1.1 Create Ticket

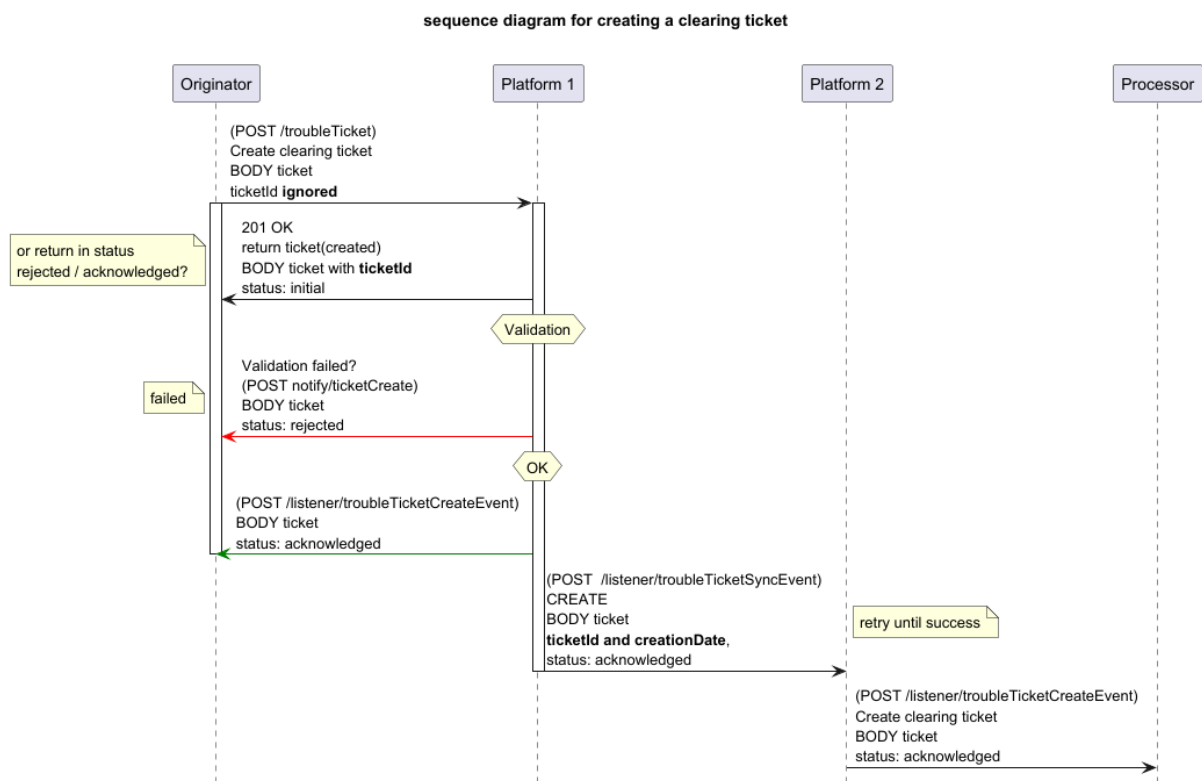

- Validation of supported scenarios shall only be performed for the receiver role of the ticket.

## Clearing Inter Platform REST API Specification

### 3.1.2 Set Status

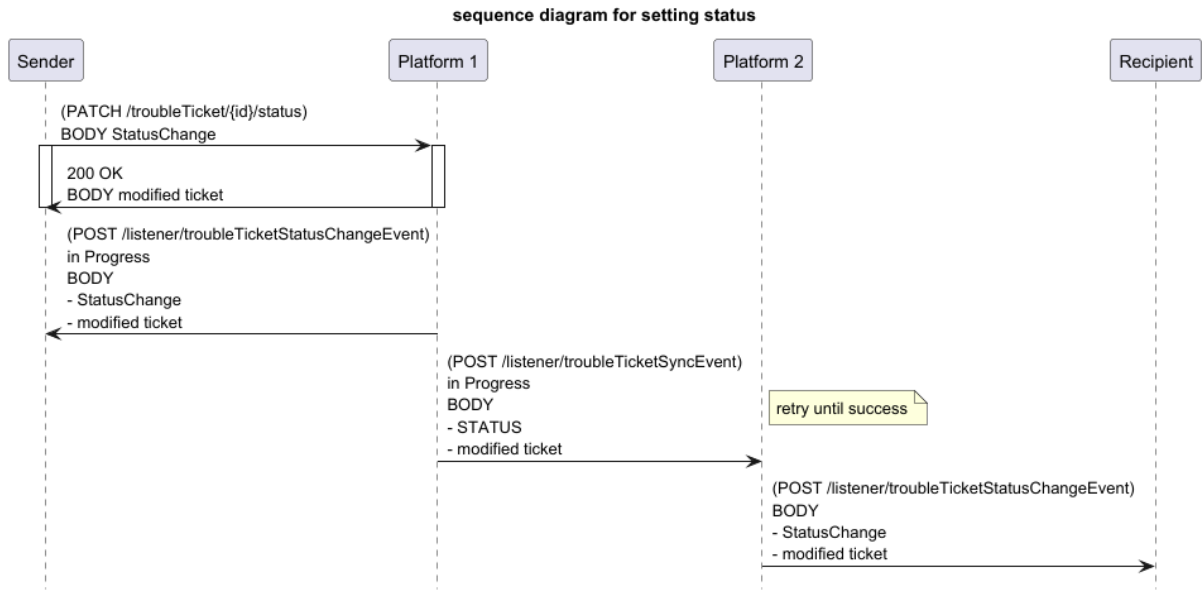

*Note: There is also no sync event for Final, since Final is not an official lifecycle event.*

### 3.1.3 Set Resolved

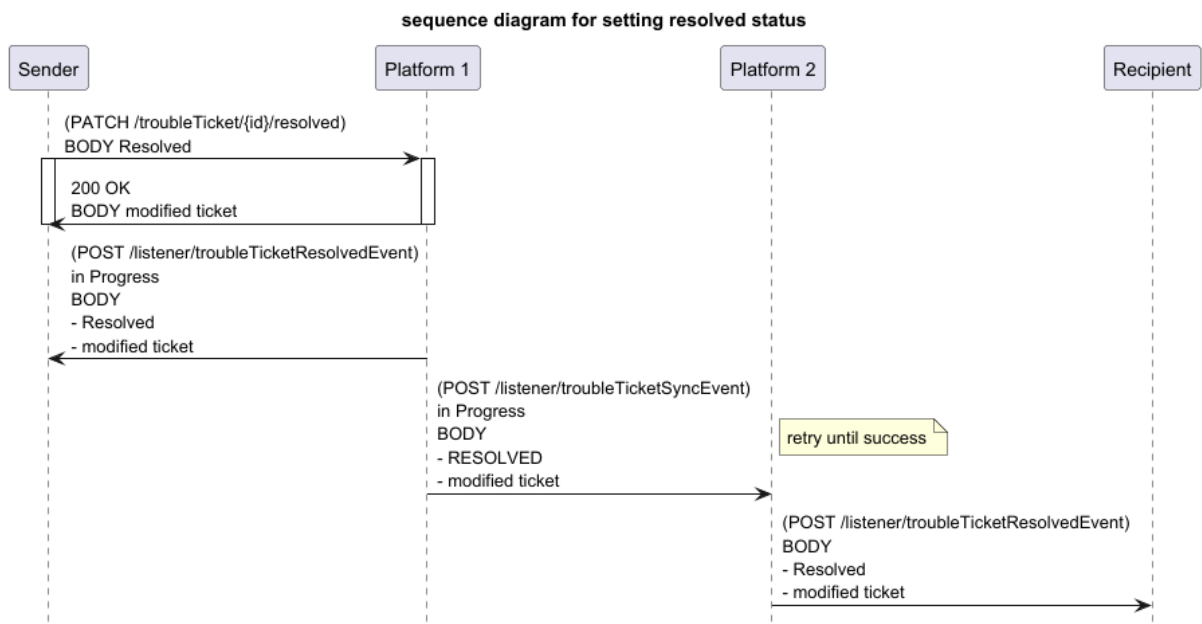

## Clearing Inter Platform REST API Specification

### 3.1.4 Change Severity

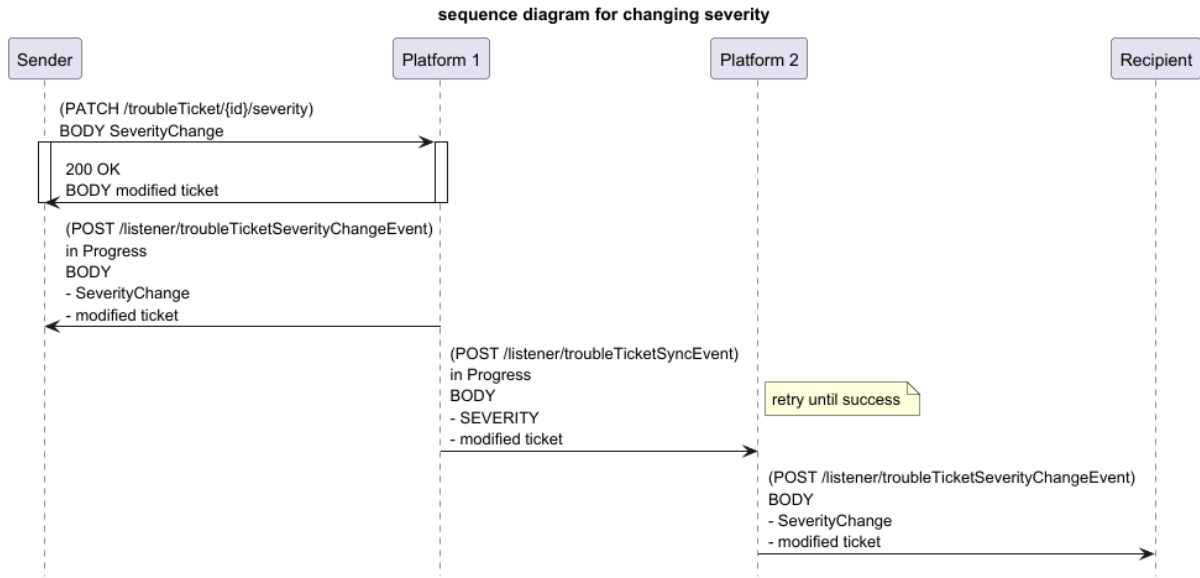

### 3.1.5 Add a Note

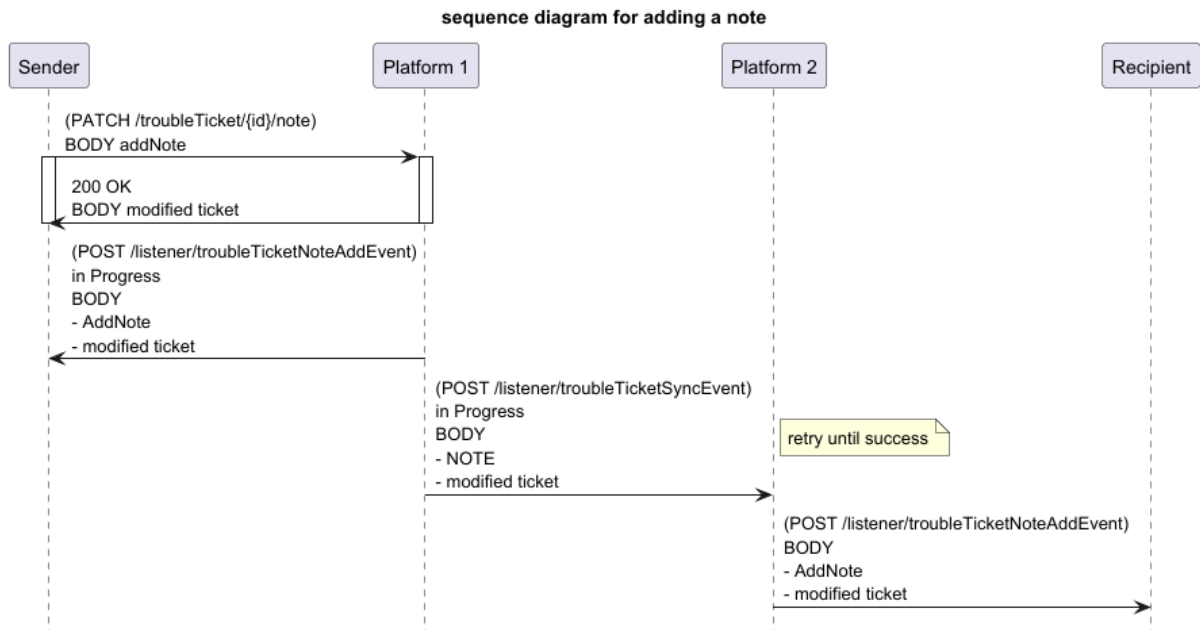

## 3.1.6 Change Data

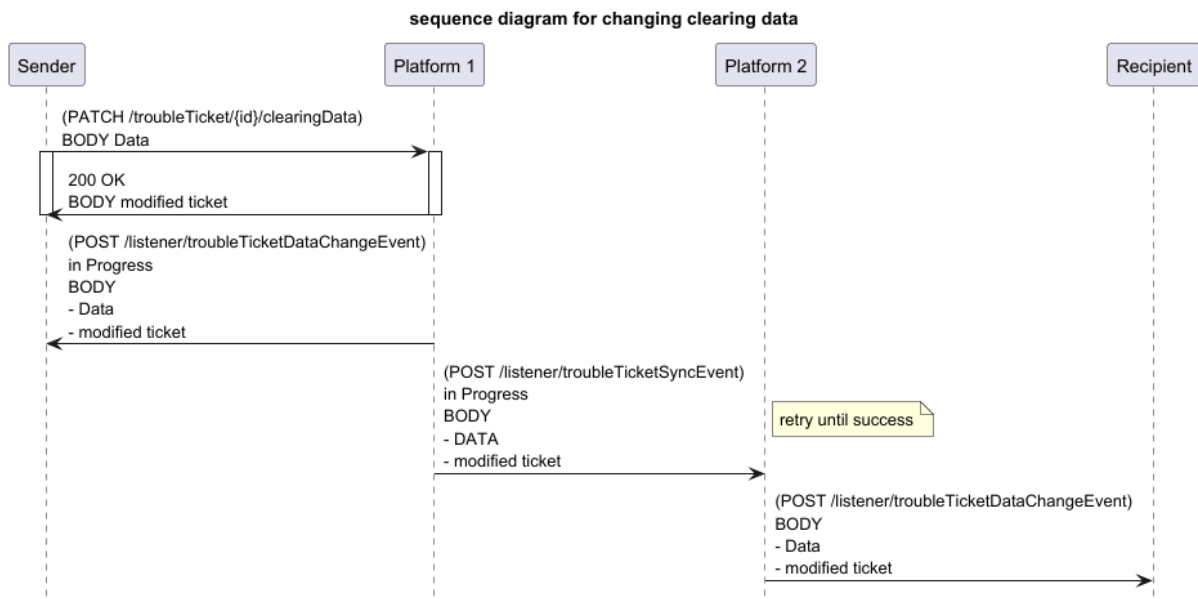

## 3.2 Request Ticket Cancellation

Cancellation ticket requests allow a processor platform to formally request the cancellation of a ticket on the connected platform during problem resolution or escalation.

```
/listener/troubleTicketCancelRequest/{id}:
  post:
    tags:
      - IpcNotificationListener
    summary: Request cancellation of a ClearingTicket
    description: This operation allows a processor to request cancellation of a ClearingTicket.
    operationId: requestTicketCancellation
    parameters:
      - name: id
        in: path
        description: Identifier of the ClearingTicket to be cancelled
        required: true
        schema:
          type: string
      - name: originatorItuCode
        in: query
        description: ITU code of the ticket's originator
        required: true
        schema:
          type: string
```

### Clearing Inter Platform REST API Specification

```

- name: reason
  in: query
  description: Optional reason for the cancellation request
  required: false
  schema:
    type: string
responses:
  '202':
    description: OK - Cancellation request accepted for processing
    content: {}
  '400':
    description: Bad request (e.g., ticket cannot be cancelled due to current
state)
    content: {}
  '404':
    description: Ticket not found
    content: {}
  '422':
    description: Unprocessable Entity (e.g., already cancelled or duplicate
request)
    content:
      application/json;charset=utf-8:
        schema:
          $ref: '#/components/schemas/SyncError'

```

#### Parameters explanation:

- **id**: Identifier of the ClearingTicket to be cancelled.
- **originatorItuCode**: ITU code of the ticket's originator.
- **reason**: cancellation reason.

#### Post-Request Handling:

Upon receiving the cancellation request at `/listener/troubleTicketCancelRequest/{id}`, the originator platform **must change the ticket state to "cancelled"** and subsequently **sync the updated ticket state with the processor platform** via the established ticket synchronization mechanism.

### 3.3 Request Customer Migration

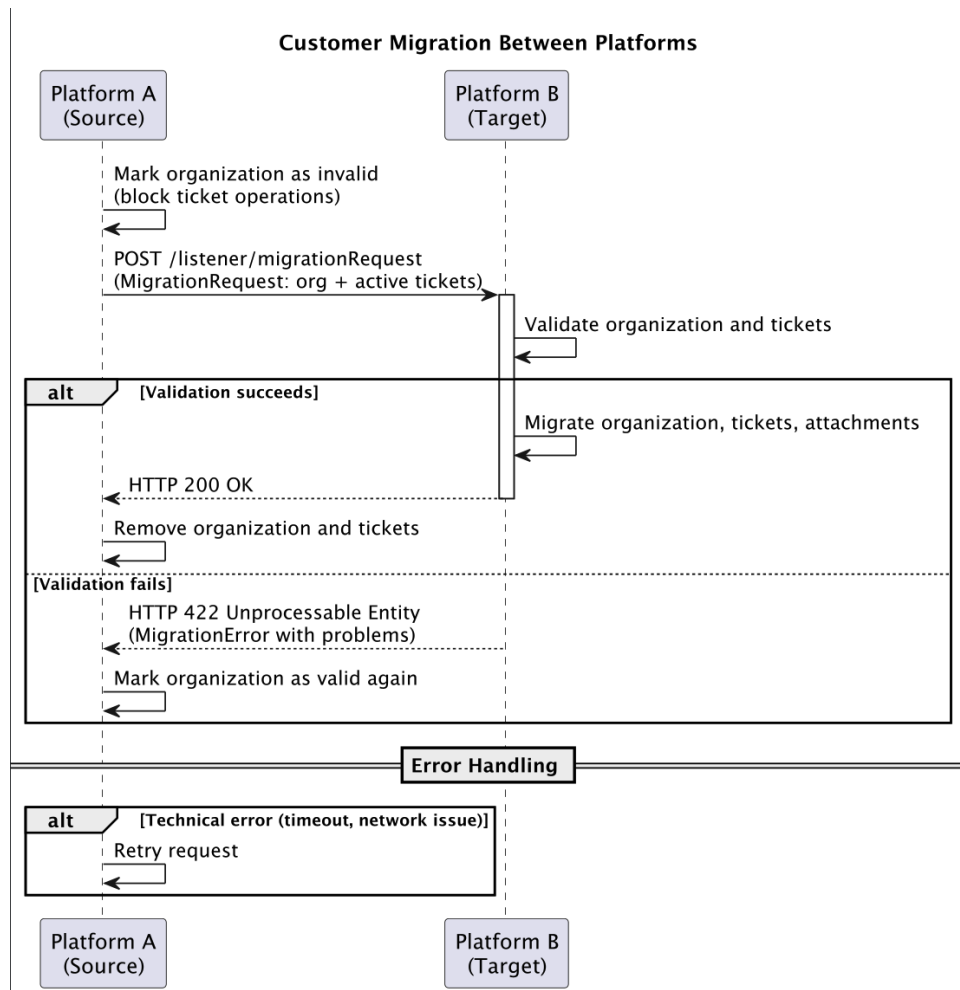

Migration request allows a platform to formally transfer an organization, including all its active tickets and related attachments, to another platform. This process is used when a customer changes its hosting platform. It ensures that the complete state of the organization is moved in a consistent way, while preserving ticket IDs for traceability across platforms.

```
/listener/migrationRequest:
  post:
    tags:
      - IpcNotificationListener
```

#### Clearing Inter Platform REST API Specification

```
summary: Initiate a migration request for an organization
requestBody:
  required: true
  content:
    application/json:
      schema:
        $ref: '#/components/schemas/MigrationRequest'
responses:
  '200':
    description: Migration succeeded. All tickets and attachments migrated,
      ticket IDs remain unchanged.
  '422':
    description: Migration failed due to validation errors. Returns list of
      detected problems.
    content:
      application/json:
        schema:
          $ref: '#/components/schemas/MigrationError'
```

The request body of type **MigrationRequest** contains:

- **The organization** to be migrated.
- **All active tickets** belonging to that organization (not closed or cancelled), each provided in full according to the most recent **ClearingTicket** specification (see [\[MAIN-1\]](#) and [\[REF-4\]](#)).
- **All attachments** related to those tickets, transferred together during the synchronous migration process.

**Reason:** The migration must guarantee that the complete state of the organization (tickets + attachments) is transferred consistently in a single operation.

**Benefit:** The receiving platform can directly replace the full dataset (organization, tickets, and attachments) and maintain traceability through unchanged ticket IDs. This ensures that the migrated organization is immediately usable on the target platform.

## 3.4 Access control

A platform may only execute any action on the ticket if either the **originator** or the **processor** of the ticket is registered on that platform.

If the caller is not a party to the ticket, the request must be rejected with an appropriate response

422 Unprocessed Entity.

# 4 Syncing carriers between platforms

Each platform owns data about its own partners and their users. It needs to share its information about their partners with all other platforms while users are only known within the respective platform, strictly separated for each partner.

**Note:** The concept of a carrier in the Inter-Platform API refers to the high-level registration of a partner (identified by an ITU Carrier Code) and the associated platform they are hosted on. This is distinct from the full carrier or partner structure defined in [\[REF-4\]](#).

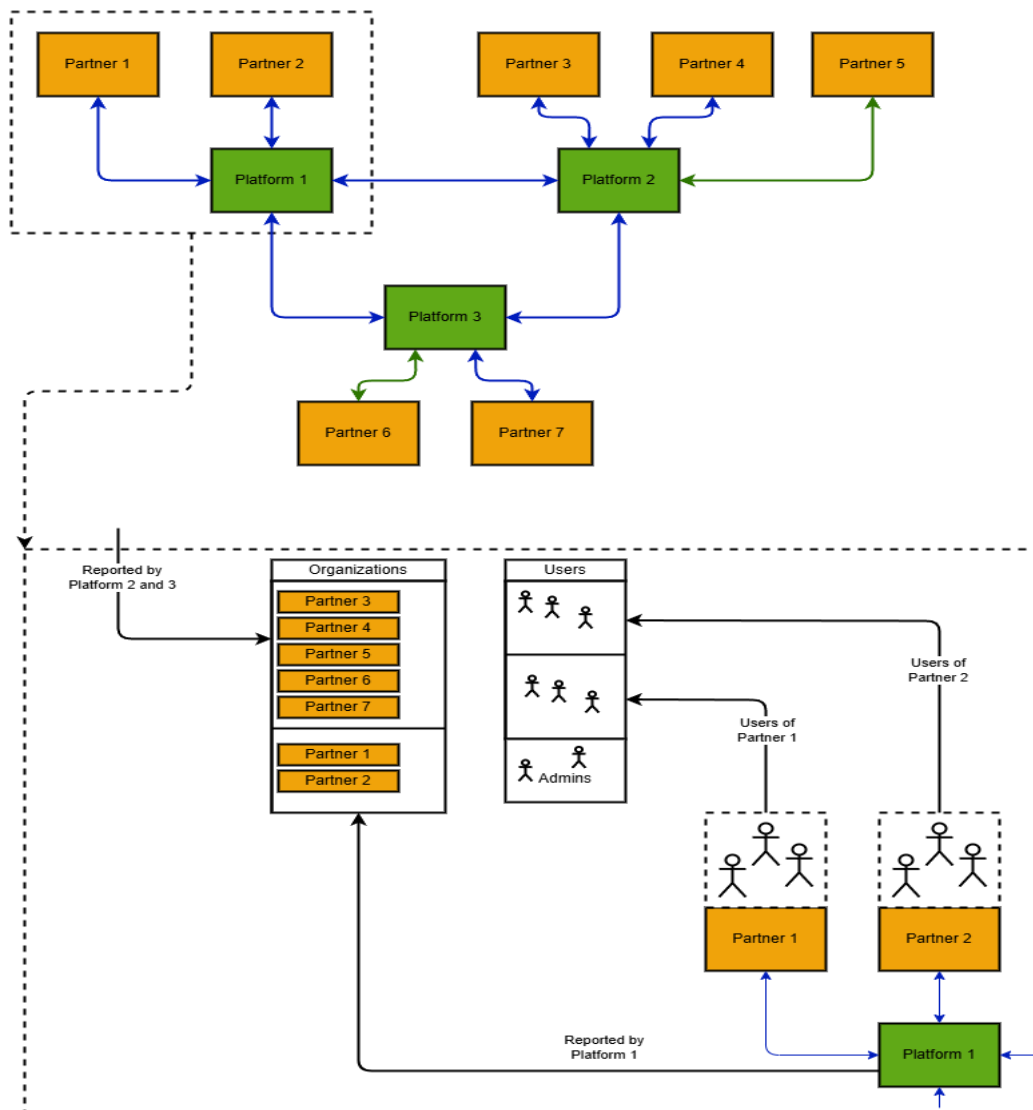

All platforms are expected to query about the latest status every hour

## Clearing Inter Platform REST API Specification

- [/carrier](#) List of carriers on the platform

In the case of an exception - the ticket to be synchronized contains an unknown carrier (usually the originator) - it must be actively checked whether the stored information about carrier/platform is possibly out of date.

- [/carrier/{id}](#) Obtain information about carrier

Carrier:

```

type: object
description: ItuCarrier
required:
  - id
properties:
  id:
    type: string
    description: Unique identifier of the ItuCarrier - DEU.XXXXX
  tradingName:
    type: string
    description: Name that the Carrier (unit) trades under
  validFrom:
    type: string
    format: date
    description: Validity of this carrier on this platform starts with
      'validFrom'
  validTo:
    type: string
    format: date
    description: Validity of this carrier on this platform ends with
      (including) 'validTo'
  flag:
    type: string
    description: Mark a special organization e.g. as demo or test
      organization
  unsupportedScenarios:
    description: List of all unsupported scenarios
    type: array
    items:
      description: Scenario ids like 1.01, no main scenario ids or wildcards
        are allowed.
      type: string

```

If a GET [/carrier/{id}](#) call returns 404 Not Found, the calling platform must assume that the carrier has been removed or de-registered, and that this change has not yet been reflected in the last hourly carrier sync.

## Clearing Inter Platform REST API Specification

In this case:

- The caller must wait until the next full sync (`GET /carrier`) to confirm the removal.
- Once confirmed, the platform must stop referencing the removed carrier and handle any dependent data (e.g., tickets) accordingly.

## 4.1 Handling of Non-Clearing Organizations (NCOs)

Currently, only registered clearing platforms and their associated carriers participate in inter-platform ticket synchronization. However, scenarios arise where **Non-Clearing Organizations (NCOs** = partners or customers not connected to any clearing platform) are involved.

Read more about **NCOs** in [Fehler! Verweisquelle konnte nicht gefunden werden.Fehler!](#)  
**Verweisquelle konnte nicht gefunden werden.**

For Inter-Platform communication, NCOs are fully ignored.

This means:

- NCOs are **never synced** between platforms.
- They are only visible to other carriers on the platform where they are introduced.
- hence, they might exist on several platforms simultaneously

As soon as a carrier, which was introduced as NCO on any platform, will then register on a platform

- If the carrier was **already** introduced as NCO on the **receiving platform**, it is just **transitioned** into a regular carrier synchronized between the platforms. It is then up to the platform how to deal with their active tickets.
- If the carrier was **not** introduced as NCO on the **receiving platform**, the registration is done regularly.
- In either case, the registration of the carrier on the receiving platform must happen according to the rules in chapter 4\_Syncing carriers between platforms.
- for all **other platforms**, where the carrier has been introduced as NCO: with the first synchronization the carrier must immediately be removed as **NCO**. It is then up to the platform to deal with their active tickets, as they can no longer be processed.

**Note:** To avoid any problems with active tickets, ideally the NCO should get rid of any active ticket beforehand and actively inform all platforms about the plan to become a registered carrier.

## 5 Attachments

Attachments also need to be accessed via API using the method

`/attachment/{id}`

It is up to the implementation whether to:

- Always retrieve an attachment from hosting platform
- Cache a copy of all those attachments locally.

If the requested attachment is not available — whether due to deletion, virus check failure, or any other issue — the platform must treat the attachment as **missing** and will not be able to render it to its customer.

## 6 Checking tickets

To ensure data consistency across platforms, each system must be able to inspect the current state of a specific ticket as maintained by the other platform. This is especially useful for troubleshooting synchronization issues or resolving conflicts during escalations.

The Inter-Platform API provides the following endpoint:

- `/troubleTicket/{id}` - Retrieves a single ticket identified by its unique ID.

**Note:** Bulk ticket query will not be supported in current version of the Inter-Platform API .

### 6.1 Access Control

A platform may only request a ticket if either the **originator** or the **processor** of the ticket is registered on that platform.

If the caller is not a party to the ticket, the request must be rejected with an appropriate response 403 Forbidden.

# 7 Operational Exception Guidelines

## 7.1 Failure Handling Principles

Errors encountered during platform communication can be categorized into the following types:

- **Technical errors** include timeouts, connection failures, and HTTP status codes in the 4xx (except 422) and 5xx ranges. These typically indicate network issues, temporary unavailability, or unexpected server errors.
- **Logical errors** request was syntactically correct but semantically invalid due to violation of Clearing specification rules.
- **Illegal requests** are errors caused by invalid request or even payload syntax.

### 7.1.1 Technical errors

On technical errors platform **must retry** the request. The idea is that the error may disappear as soon as some action is taken by the receiver of the request.

If retries are unsuccessful after a certain number of attempts or time interval, the platform **must inform** the other platform via **email** and the issue must be resolved by **involved parties** through coordination.

*The number of retries and the interval between retries are not specified in this document and shall be defined operationally*

In such cases, the following escalation procedure shall be applied:

1. Email notification to the other platform
2. The affected platform must resolve the problem within a reasonable amount of time
3. If affected platform is not agreeing to solve the problem at all or in time: escalate to Working group.

### 7.1.2 Logical errors

On logical errors the receiving platform must respond with HTTP status code **422 (Unprocessable Entity)** to indicate that the request was syntactically correct but violated clearing specification or ticket state conflicts and the reason for the error must be provided in the reason field. The platform

#### Clearing Inter Platform REST API Specification

must cancel the ticket automatically (if originator) or request cancellation of the ticket as described in [Request Ticket Cancellation](#), both with a proper “cancel reason” e.g. “We are unable to process the ticket due to a logical issue between platforms. Please try again later.”

In such cases, the following escalation procedure shall be applied:

1. Email notification to the other platform
2. Attempt resolution of the problem through direct contact and clarification between the involved platforms, including manual reconciliation of ticket states if cancellation synchronisation fails.
3. If none of the platforms are agreeing to solve the problem escalate to Working group.

### 7.1.3 Illegal requests

- Requests considered **illegal** (e.g., invalid parameters or operations) must be **immediately rejected** and response for such requests must be HTTPS status code 400 (Bad Request)
- If the illegal request is **expected per specification**, the receiving platform shall handle it according to the spec.
- If the illegal request is **unexpected**, the platform shall follow the [Unexpected situations](#) defined.

## 7.2 Unexpected situations

- When cancellation and resolved states conflict, the **“cancelled”** state must prevail and platforms must allow switching ticket state from resolved to cancelled in this case.
- For unexpected error, ticket will be automatically cancelled same as for [logical errors](#)

# 8 Customer Migration Between Platforms

The migration of an organization from one clearing platform to another is a coordinated process between the two platforms

- the platform which will be left by the migrating organization: **Platform A**
- the platform the migrating organization will move to: **Platform B**

The goal is to ensure that all active tickets belonging to the migrating organization are transferred.

## 8.1 Preconditions

- There must be an official request of the migrating organization stating an earliest date.
- The migration must be administratively and informally agreed between the two platform operators, e.g. via email exchange. Hence, the receiving platform must authorize the organization's migration.
- As a best practice, a cutover window (e.g., Friday afternoon → Monday morning) is defined to minimize operational risk.

## 8.2 Process overview

At the scheduled time, Platform A will mark the migration organization as invalid to avoid ticket operations during the migration. Then

Platform A will call the `/listener/migrationRequest` API of Platform B synchronously, see chapter 3.3 [Request Customer Migration](#).

The request specifies the organization and the list of all *active* tickets, where active means they are not *closed* or *cancelled*.

The receiving Platform B validates the request and checks if migration is allowed, and all tickets are valid.

If **check succeeds**, Platform B will then proceed with the migration of the organization, its tickets, and their attachments and then return with HTTP status code `200 OK`. Ticket IDs remain unchanged, preserving traceability across platforms.

On successful migration, Platform A will then proceed with removing the organization and all its tickets. From this point on, the organization is hosted exclusively on the new (target) platform. All new tickets involving the organization are created and maintained on the receiving platform only.

If **check fails**, Platform B returns with HTTP status code `422 Unprocessable entity` along with a list of **all** detected problems. Platform A will then proceed with just marking the migrating organization as valid again.

## 8.3 Migration error handling

The migration is triggered by an operator via a synchronous request.

So, there will be an instant feedback, if the request fails

- Technical errors, e.g., communication timeouts are just retried.
- Logical errors, e.g., invalid organization, invalid ticket(s) result in a HTTP status code `422 Unprocessable entity`. The reported errors need to be clarified bilaterally between the platform operators. After solving the problems that led to this error, the migration is to be rescheduled.

## 9 Open Issues

Open issues are not part of the current specification and are tracked separately.

Immediately after the current version of the specification has been implemented the open issues need to be resolved and the next implementation must take care of the adjustments.

### 9.1 Unexpected situations

Even if the specification tries to cover all possible exceptions there is still room for unexpected situations. Here is a short list of those situations:

- An **illegal request** is indicated by the receiving platform but the calling platform claims that the request is legal according to the rules. Here we again need an escalation strategy
- ...

### 9.2 Automatic cancellation

Currently, if cancellation synchronization between platforms fails (e.g., due to a 422 error or a subsequent sync failure), ticket states must be reconciled manually by the involved platforms as part of the escalation procedure [Cancellation reconciliation](#).

**Open Issue:** Define and implement an automated reconciliation mechanism to detect and align mismatched cancellation states between platforms, thereby eliminating the need for manual intervention in these cases.

### 9.3 Other Topics

This specification does not handle the scenario, where a ticket is updated from both ends at the same time. How is a collision handled? To me a collision may not even be noticed in this specification. (This can happen, if the communication of the platform is interrupted).

# 10 Change Log

## 10.1 Version 1.0 to Version 1.1

### Introduction of new attribute **unsupportedScenarios**.

- This new attribute contains a list of scenario ids which are not supported by a Carrier. See: [3](#) [Syncing carriers between platforms](#)
- Added **x-compatibility** to define a machine readable version matrix and policy for Inter Platform/Clearing Platform compatibility and required version bumps on referenced model changes.

## 10.2 Version 1.1 to Version 1.1.1

Clarified that supported scenario validation in inter platform communication applies only to the receiver role of the ticket.

See: [3.1.1 - Create Ticket](#)